



Bobcat[®]

One Tough Animal.

COMPACT EXCAVATORS

E08, E10z

0-1t | 1-2t | 2-3t | 3-4t | 4-6t | 6-10t



INTRODUCTION

ONE TOUGH ANIMAL



BOBCAT'S HISTORY

In 1958, Melroe Manufacturing Company introduced a compact front-end loader that evolved quickly into the M400, the world's first true skid steer loader. The company soon adopted what became the world-famous 'Bobcat' brand – and its success paved the way for the global compact equipment industry we know today.

INNOVATION CENTER IN DOBRÍŠ

New technologies and machines are rigorously tested to take on the toughest jobs.



BOBCAT TODAY

Since developing micro excavators with Zero-House Swing functionality in 1984, Bobcat has continued to innovate. Today, our equipment is known for providing all the power you need, where you need it, without extra hassle.

OUR MISSION

We empower operators to accomplish more, while working in the toughest conditions and tightest situations. When our customers have the will, we provide the way.



MARKET'S #1 CHOICE

► **WHERE LARGE MACHINES CANNOT FIT**
 Micro excavator with best-in-class combination of performance, operator comfort and stability, while maintaining the necessary compactness.



► **TRANSPORTABILITY**
 Both models are easily towable on most trailers behind a standard passenger car.



► **STABILITY**
 Exceptional stability thanks to the widest undercarriage profile on the market in extended position.
P. 7



► **COMFORT**
 Pilot controls and patented adjustable consoles improve comfort and help you work longer and with less fatigue.
P. 8



► **PERFORMANCE**
 Conquer any challenge with ease with optional hydraulic oil cooler and pilot controls.
P. 7



PERFORMANCE



▶ ADVANCED COOLING SYSTEM

Don't let the heat distract you from your job. Advanced cooling performance with optional hydraulic oil cooler means that your machine will stay cool and productive even in the most demanding applications.

▶ PRACTICAL AND VERSATILE

Designed to excel in a wide range of applications thanks to outstanding 360° stability. With the widest track profile on the market in the extended undercarriage position, both working range and lifting capacities get a major boost.



POWER WHERE YOU NEED IT

▶ NIMBLE AND FAST

Travel around the job site in no time – thanks to 2-speed and high-torque travel motors. Precise maneuvering, even when running at full power, increases your productivity significantly.



▶ LIMITED ACCESS IS ACCESS ENOUGH

With Zero House functionality, even with ROPS protective structure extended, Bobcat machines allow operators to work in constrained environments, in extreme proximity to walls and other challenging situations.

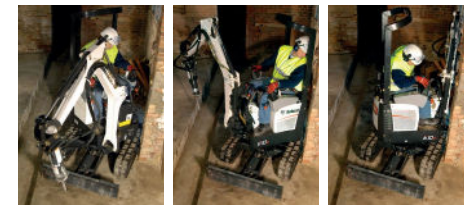

TAKE CONTROL



PILOT CONTROLS

Take comfort and controllability even further with pilot controls. The selectable control patterns allow you to control the machine in your preferred way.



OPTIMIZED FOR COMFORT



Low noise and vibration levels ensure excellent operator comfort along with reduced environmental impact.

READY FROM DAY ONE



Equipped with expandable undercarriage and blade as standard. There is no need to remove and reinstall the blade extensions.



BUILT TO LAST



MADE TO KEEP YOU IN THE FIELD

- Cylinder over the boom design for improved uptime protection
- All metal covers for high durability.
- Optional cylinder covers and heavy-duty travel hose guards for uptime in demolition.
- Materials, components and structures have been tested stringently for endurance under extreme conditions.

SIMPLE MAINTENANCE

Wide tailgate opening for easy maintenance and serviceability.

STANDARD WARRANTY

Bobcat Company develops every machine to the highest standards of quality and durability. That's why our standard warranty provides 24 months or 2000 operating hours (whichever occurs first) of coverage.



PROTECTION PLUS EXTENDED WARRANTY

Enjoy total peace of mind with a Protection Plus® extended warranty. Providing the same level of protection as the standard warranty, Protection Plus also reflects different customer needs and expectations by offering a choice of durations and annual operating hours. According to your needs, you can benefit from the coverage for up to 5 years or 6000 engine hours. And Protection Plus is transferrable – so it will likely increase your machine's resale value.



BOBCARE

A long-running machine starts with proper planned maintenance. And it helps protect against repair costs and unplanned failures when you're counting on your machine to work.

- Avoid risk by preventing major repairs and complete failures.
- Accomplish more by reducing downtime and increasing your productivity and profitability.

STANDARD EQUIPMENT & OPTIONS

	E08	E10z
PERFORMANCE		
Auxiliary double action	•	•
Auxiliary hydraulics on boom with quick couplers	•	✓
Auxiliary hydraulics on boom with caps	✓	–
Auxiliary on arm with caps or quick coupler	•	•
Hydraulic oil cooler	•	•
Object handling device (lifteye)	•	•
Spark arrester muffler kit	kit only	kit only
Two-speed travel	–	✓
SEAT & CONTROLS		
Control console locks	✓	✓
Keyless ignition	✓	•
Retractable seat belt	✓	✓
Seat	✓	✓
TOPS canopy*	✓	✓
UNDERCARRIAGE & TRACKS & DOZER BLADE		
180 mm rubber track	✓	✓
710 mm dozer blade / 1 000 mm extended	✓	–
710 mm dozer blade / 1 100 mm extended	–	✓
Hydraulically expandible undercarriage from 710 to 1 000 mm	✓	–
Hydraulically expandible undercarriage from 710 to 1 100 mm	–	✓
Electronically activated track expansion	–	✓
LIGHTS & BEACON		
LED light	–	•
Work light	✓	✓
Beacon	•	•
MISCELLANEOUS		
Cylinder covers (arm and bucket)*	•	•
Heavy duty travel hose guard*	•	•
Horn	✓	✓
Travel motion alarm	•	•
Vandalism protection	✓	✓
Water separator	✓	✓
Grease gun with holder	•	•

• = option ✓ = standard

*included in Demolition package

PERSONALISE YOUR MACHINE

Sometimes, we all want to add a specific functionality or a personal touch to the machine. Choose from a list of comprehensive options and customise your Mini-Excavator to your heart's content!



Cylinder covers

Keyless ignition

Hydraulic oil cooler



Digging bucket

Breaker



SPECIFICATIONS

SPECIFICATIONS		
	E08	E10z
WEIGHTS		
Operating weight with TOPS canopy and bucket (ISO 6016)	1 138 kg	1 176 kg
ENGINE		
Make / model	Kubota / D722-E4B (Stage V)	
Fuel	Diesel	
Cooling	Liquid, forced circulation	
Number of cylinders	3	
Displacement	0.72 L	
Maximum power @ 2000 RPM (ISO 14396)	7.5 kW	
Maximum torque (SAE)	40.1 Nm	
CONTROLS		
Steering	Direction and speed controlled by two hand levers	
Hydraulics	Two levers control boom, bucket, arm and upper structure slew	Two joysticks control boom, bucket, arm and upper structure slew
HYDRAULIC SYSTEM		
Pump type	Double gear pump	
Pump capacity	20 L/min	
Auxiliary flow	20 L/min	
Auxiliary relief	185.0 bar	190 bar
Control valve	9-spool parallel type, open center	
PERFORMANCE		
Digging force, arm (ISO 6015)	5 550 N	
Digging force, bucket (ISO 6015)	8 294 N	
Drawbar pull	9 905 N	
Ground pressure with rubber tracks	28.8 kPa	29.7 kPa
Travel speed, low range	2.1 km/h	
Travel speed, high range	–	3.1 km/h
SLEW SYSTEM		
Boom swing, left	67°	
Boom swing, right	64°	
Slew rate	9 RPM	
BRAKES		
Travel brake	Hydraulic lock in motor circuit	
Slew brake	Hydraulic lock on motor and pin lock	
FLUID CAPACITIES		
Cooling system	3 L	
Engine lubrication plus oil filter	3.5 L	
Fuel reservoir	16 L	
Hydraulic reservoir	2.6 L	
Hydraulic system	9.4 L	10.1 L
ENVIRONMENTAL		
Noise level LpA (EU Directive 2006/42/EC)	80 dB(A)	
Noise level LwA (EU Directive 2000/14/EC)	93 dB(A)	
Whole body vibration (ISO 2631-1)	0.72 ms ⁻²	0.68 ms ⁻²
Hand-arm vibration (ISO 5349-1)	1.19 ms ⁻²	0.7 ms ⁻²

Certain specification(s) are based on engineering calculations and are not actual measurements. Specification(s) are provided for comparison purposes only and are subject to change without notice. Specification(s) for your individual Bobcat equipment will vary based on normal variations in design, manufacturing, operating conditions, and other factors. Pictures of Bobcat units may show other than standard equipment.

SPECIFICATIONS

WORKING RANGE

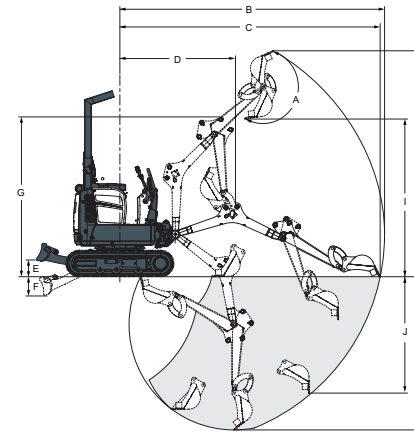

	E08	E10z
A Bucket pivot angle	196°	
B Maximum reach of working equipment	3145	
C Maximum reach at ground level	3093	
D Max. working equipment radius with boom at max. height and arm fully retracted	1374	
E Maximum blade height	196	
F Maximum blade depth	230	
G Maximum height of working equipment with arm retracted	1899	
H Maximum bucket tooth height	2685	
I Maximum dump height	1818	
J Maximum depth of vertical wall which can be excavated	1383	
K Maximum digging depth	1820	

LIFTING CAPACITIES

RATED LIFT CAPACITY AT 2000 MM LIFT RADIUS [R] (KG) BLADE UP, 360°

LIFT POINT HEIGHT [H] (MM)	WITHOUT CYLINDER COVERS		WITH CYLINDER COVERS	
	E08	E10z	E08	E10z
2000	177	212	175	211
1000	180	214	176	216
Ground	172	204	159	206
-1000	191	229	176	228

Rated hydraulic lift capacity. The lifting capacities are based on ISO 10567 and do not exceed 75% of the static tilt load of the machine or 87% of the hydraulic lifting capacity of the machine.

DIMENSIONS

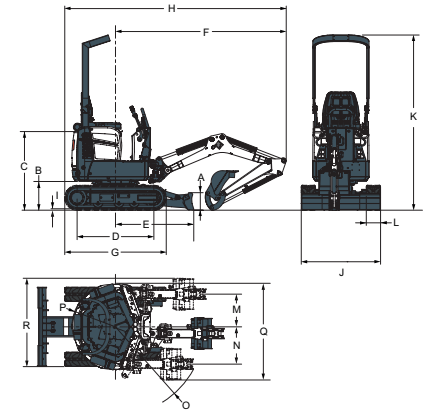

	E08	E10z		E08	E10z
A	220		J	1000	1100
B	363		K	2209	
C	992		L	180	
D	968		M	413	
E	987		N	471	
F	2153		O	1121	
G	1280		P	550	
H	2793		Q	1221	
I	16		R	1162	
J	710		Boom length	1276	
			Arm length	810	

Unit: mm

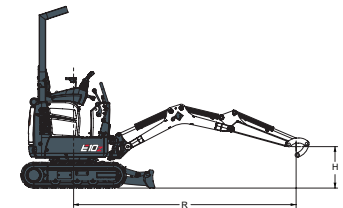

FINANCING OPTIONS

24, 36, OR 48 MONTH FINANCING*

Take advantage of 24, 36 or 48 month financing programs starting from **0% interest** and improve your cashflow. Ask your dealer for the financing offers available.

100 MACHINES / 150 ATTACHMENT FAMILIES / 1 TOUGH ANIMAL



**SKID STEER
LOADERS**



**COMPACT TRACK
LOADERS**

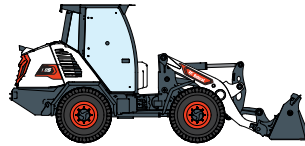

**COMPACT WHEEL
LOADERS**



**SMALL ARTICULATED
LOADERS**

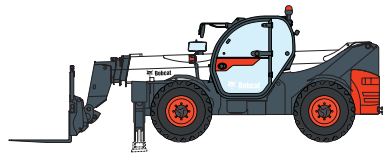

TELEHANDLERS

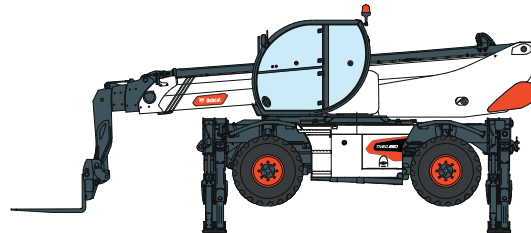

**ROTARY TELESCOPIC
HANDLERS**



**LIGHT COMPACTION
EQUIPMENT**



**MINI TRACK
LOADER**



COMPACT EXCAVATORS

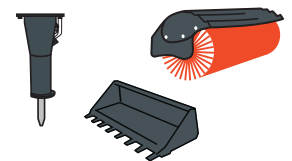

ATTACHMENTS



www.bobcat.com

Bobcat is a Doosan Company. Doosan is a global leader in construction equipment, power & water solutions, engines, and engineering proudly serving customers and communities for more than a century. | Bobcat and the Bobcat logo are registered trademarks of Bobcat Company in the United States and various other countries. ©2021 Bobcat Company. All Rights Reserved.

©2021 BOBCAT B4501512-EN (10-21)



Bobcat®

*Financing options may vary by country and dealer. Always ask your dealer about currently available financing options. Terms and conditions may apply.

Doosan Bobcat EMEA, U Kodelky 1810, 263 12 Dobříš, Czech Republic

